

GGB-DB[®]

**SELF-LUBRICATING
BRONZE BEARING SOLUTIONS**

 **GGB**

Content

The GGB Advantage	3	5	Forms and Dimensions	17
Quality / Certification	3	6	Installation	18
GGB History	4	7	Radial Bearings - Flanged Bushes - Thrust Washers	21
1 Introduction	6	8	Spherical Bearings - Standard C Series	22
1.1 GGB-DB® Structure	6	9	Spherical Bearings - Standard E Series	24
1.2 GGB-DB® Properties and Advantages	7	10	Spherical Bearings - Standard G Series	25
1.3 Applications	8	11	Spherical Bearings - Standard H Series	26
1.4 Available Forms	9		Bearing Application Data Sheet	28
2 GGB-DB® in Operation	10		Product Information	29
2.1 GGB-DB® Solid Lubricants	11		Company History	30
2.2 Running-in Film GGB-DB®	11			
2.3 Wear and Friction Properties	11			
3 Technical Data	12			
3.1 GGB-DB® Standard Bronze Alloys	12			
3.2 Fits and Tolerances	13			
3.3 Mating Material	13			
4 GGB-DB® Design Factors	14			
4.1 Specific Load	14			
4.2 Sliding Speed	14			
4.3 pU Factor	15			
4.4 Material Selection	15			
4.5 Lifetime Estimation	16			

GGB-DB®

THE GGB ADVANTAGE

With manufacturing facilities around the world, including cutting edge R&D facilities, flexible production platforms and extensive customer support networks, GGB offers unmatched technical expertise combined with razor sharp responsiveness and customized solutions. Our global presence and local logistics networks ensure our customers receive only the highest quality bearing solutions, in a timely manner and with extensive engineering support. We don't just make products, we build partnerships. That's the GGB Advantage.

QUALITY / CERTIFICATION

Our world-class manufacturing plants in the United States, Brazil, China, Germany, France and Slovakia are

CERTIFIED IN QUALITY AND EXCELLENCE IN THE INDUSTRY

according to ISO 9001, IATF 16949, ISO 14001 and ISO 45001.

This allows us to access the industry's best practices while aligning our quality management system with global standards.

For a complete listing of our certifications, please visit our website:

<https://www.ggbearings.com/en/certificates>

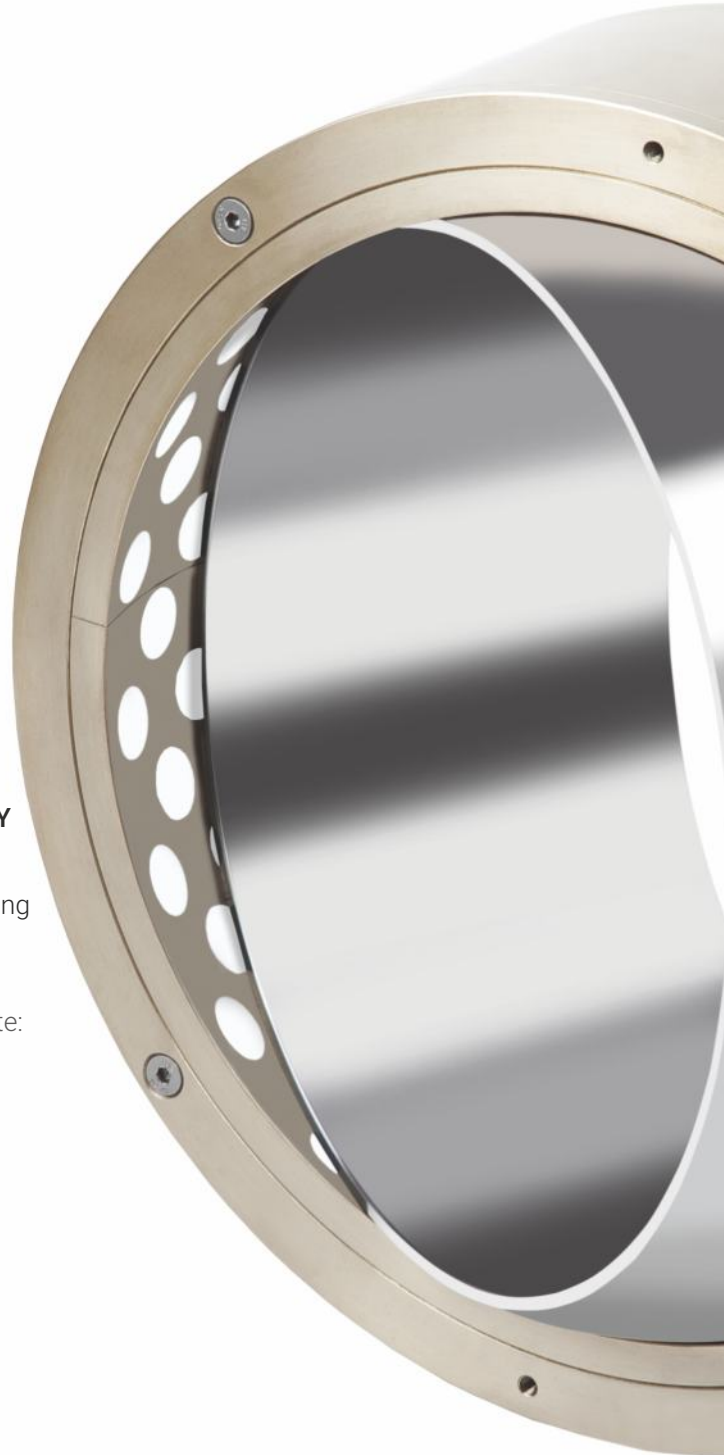

A Long History of Innovation

FROM OUR MODEST BEGINNINGS OVER 120 YEARS AGO, GGB GREW THROUGH INNOVATION AND TECHNICAL EXPERTISE TO BECOME THE WORLD'S LEADING MANUFACTURER OF PLAIN BEARING SOLUTIONS.



1899
Findlay and Battle founded Findlay Motor Metals. The company was renamed to Glacier Antifriction Metal Company two years later.

1910s
Began making plain bearings in response to increased demand for internal combustion engines.

1956
Introduced DU®, the world's first steel backed metal-polymer bearing material with bronze and PTFE lining offering excellent low friction and wear resistance performance. Introduced DU-B with bronze backing for improved corrosion resistance.

1958
Garlock Inc. was founded as a bearing distributor when an agreement was reached with Glacier.

1965
Launched the marginally lubricated DX® metal-polymer material for greased applications.

1970s
Glacier licensed technology to a number of overseas bearing manufacturers. Licenses included: SIC (France), Garlock Bearings (USA).

2004
Glacier Garlock Bearings changed name to GGB. Opened new manufacturing plant Sučany, Slovakia.

2007
Introduced SBC (Sealed Bearing Cartridges) for off-highway equipment applications. Acquired Böhlinger Kunststofftechnik GmbH precision injection molder of high-performance solid polymer solutions.

2008
Production facility opened in Suzhou, China; new DX®10 bearings won Frost & Sullivan's product innovation of the year award in the Class 7-8 truck bearings category.

2009
Filament-wound product range introduced to the European and Asian markets; GGB North America certified to AS9100B, the aerospace industry's standard for quality management systems.

2010
Introduced lead-free DP10 and DP11 metal-polymer materials for superior performance under marginally lubricated and dry running conditions.

2011
Acquired PI Bearing Technologies, now GGB Chicago, a producer of PICAL® aluminum alloy bushing blocks for demanding fluid power applications. GGB plants certified to OHS18001 for health and safety management systems.

2012
DTS10® machinable metal-polymer bearings are launched for the fluid power and compressor markets. GGB bearings land on Mars aboard NASA's Curiosity rover.

2013
Launched new self-lubricating metallic bearing materials GGB-CSM® and GGB-CBM® as well as FLASH-CLICK® two-piece, double-flanged solid polymer bearings.



1978

Introduced filament wound product range in the USA, including GAR-MAX®.

1976

Glacier and Garlock Inc. establish joint venture company Garlock Bearings Inc.

1995

Introduced lead-free steel backed DP4 metal-polymer material for automotive shock absorbers and other hydraulic applications. Introduced DP4-B with bronze backing for improved corrosion resistance.



1998

Manufacture of plain bearings exceeds one billion pieces per year



2003

Introduced lead-free DP31 metal-polymer material with improved performance under lubricated conditions. Acquired Saver North America, a producer of self-lubricating composite bearings. Glacier Garlock Bearings expanded business in Asia.

1986

Launched HI-EX® metal-polymer material, designed for high temperature applications



1996

Launched new range of EP® engineered plastic bearings



2002

Goodrich Corporation spun off its engineered industrial products division, creating EnPro Industries Inc., the new parent company of Glacier Garlock Bearings.

2015

Introduced HPMB®, a fully machinable, made-to-order filament wound bearing material. Also introduced the lead-free GGB-SZ, for high specific loads with low-frequency, oscillating motion.

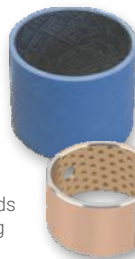

2018

Introduced EP®30 solid polymer material for hydrodynamic applications.



2021

GGB goes to Mars again on the Perseverance Rover



2016

Introduced GGB-SHB® case hardened steel bearings.



2019

Introduced UV-resistant EP®15 plastic bearing material



Launched tribological TriboShield™ range of polymer coatings



Introduced high temperature PyroSlide™ plain bearing solutions



1 Introduction

Today's equipment and systems place enormous demands on bearing performance and economics. Not only are bearings expected to perform under increasingly challenging conditions with minimal to no maintenance, they are also expected to deliver greater reliability, longer service life and lower cost of ownership.

Self-lubricating, maintenance-free GGB-DB® bearings are designed for applications with high specific loads, long dwell periods under static loading, and low sliding speeds, as well as applications that cannot be conventionally lubricated. In addition, they can be used to replace existing greased bearings.

Since 1899 GGB brings experience and accumulated expertise in self-lubricating bearings, offering extensive bearing materials and technical application knowledge across a wide range of industries. Our application engineering team can provide assistance in:

- Selection of the optimal type of bearing for your application
- Design with either standard or custom products
- Calculation of estimated life expectancy
- Assembly and installation

GGB offers the most advanced bearing materials in the industry, supported by laboratory testing in state-of-the-art facilities, produced to the highest quality standard.

1.1 GGB-DB® STRUCTURE

GGB-DB® bearings consist of a support structure cast from one of four available high-quality bronze alloys. Embedded in this structure are solid lubricant inserts or plugs, providing continuous lubrication for low friction and wear rates and long service life.

The inserts, supplemented with an applied running-in film, are arranged for optimal distribution of the lubricant over the life of the bearing. This structure provides an ultra-low coefficient of friction, maximum wear resistance, extended service and corrosion resistance, even in wet, dirty environments and exposure to seawater.

The bronze alloy and lubricant selected for a particular bearing are based on the requirements of the specific application and operating conditions.

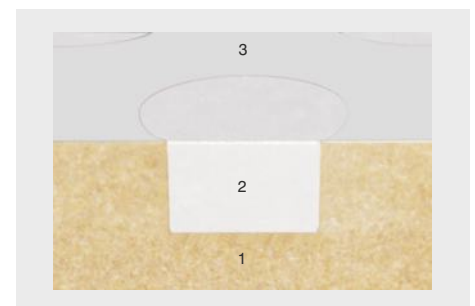

- 1 Support (bronze)
- 2 Solid lubricant insert
- 3 Sliding surface with running-in film

1.2 GGB-DB® PROPERTIES AND ADVANTAGES

- Maintenance-free operation
- High load capacity
- Excellent performance under high loads and intermittent movements
- Solid lubricant with superior performance
- Low coefficient of friction
- Negligible stick-slip effect
- Low wear rate for long life

It is recommended that the maximum permissible load be confirmed by testing under the operation conditions.

PROPERTIES	UNITS	GGB-DB®-B	GGB-DB®-C	GGB-DB®-D
Max. permissible static load p	MPa	140	350	400
Max. permissible dynamic load p	MPa	70	200	250
Max. sliding speed U	m/s		0,5	
Maximum pU	MPa x m/s	1,0	1,0	1,5
Max. temperature	°C	250	320	350
Min. temperature	°C		-100	
Friction coefficient f (dry)			0,05 - 0,18	
Min. shaft hardness	HB	180	300	
Shaft surface finish Ra (ground)	µm		0,2 - 0,8	

Table 1: GGB-DB® Properties

1.3 APPLICATIONS

Potential applications for GGB-DB® bearings include but are not limited to hydromechanical equipment such as segment, miter and emergency gates, slewing rings, wind power components, large valves, heavy machinery, cranes and conveyors, mining, construction, agricultural and other off-road equipment.

The bearings are also suitable for use in iron foundries, steel plants, offshore installations and civil engineering projects such as bridges and other structures.



1.4 AVAILABLE FORMS



Cylindrical bushes



Flanged bushes



Half bearings

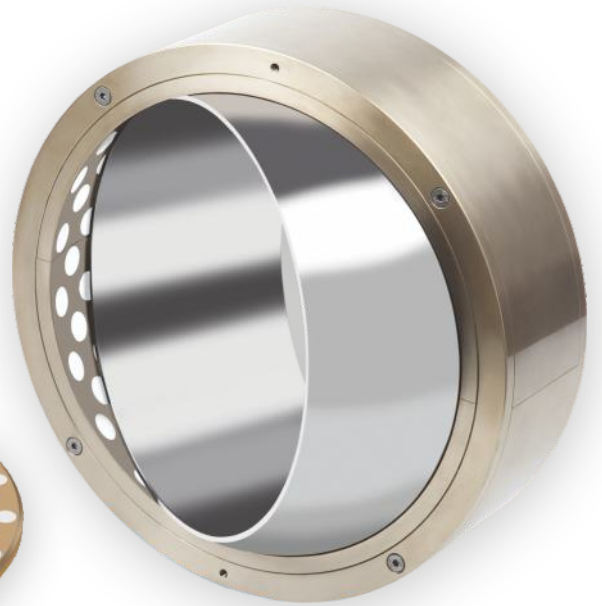

Self-aligning bearings



Slide plates

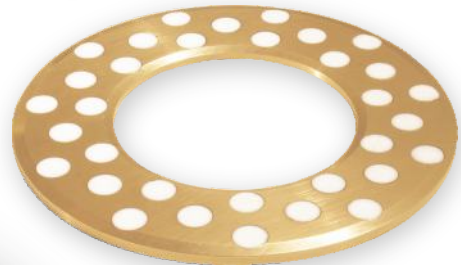

Thrust washers



Pintle bearings

2 GGB-DB[®] in Operation

UNLUBRICATED OPERATION

Two solid surfaces sliding against one another produce friction resulting in wear. This friction in turn is a result of:

- Surface adhesion or micro-welding
- Plowing or penetration by surface asperities or third-body particles
- Surface deformation

Adhesive wear results from the formation and destruction of localized bonds at the mating surfaces. To continue sliding, the surfaces must shear the weakest planes in the areas of contact. This process of repeated bonding and separation results in material loss and wear.

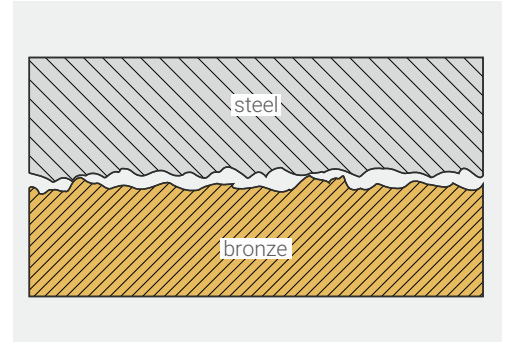

OPERATION WITH EXTERNAL LUBRICATION

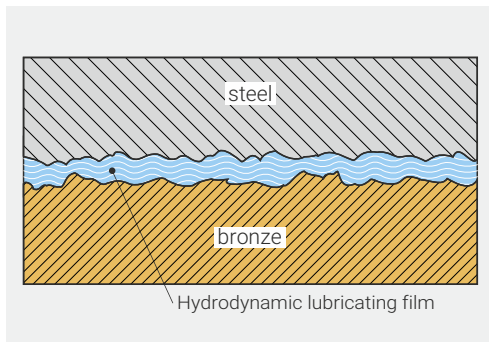

The self-lubricating properties of GGB-DB[®] bearings offer improved overall performance compared with conventionally lubricated bearings, particularly where external lubrication with grease or oil is difficult to maintain. These lubricants can be expelled from the contact zone under high loads, during long dwell periods, under static contact, or even under normal rotating or oscillating motion. This lubricant starvation often results in higher friction, damaging wear and premature bearing failure.

OPERATION WITH SOLID LUBRICANT

The use of polymers and other solid lubricants reduces adhesive friction and wear between sliding metal surfaces. The running-in film and PTFE or graphite inserts in GGB-DB[®] bearings separate their sliding layers from mating surfaces. The bearings are designed to maintain a solid lubricating film even when they are not moving. This ensures low friction and wear even under high static loads. By delivering a constant supply of solid lubricant, the bearings provide consistent friction and wear performance over their useful life.

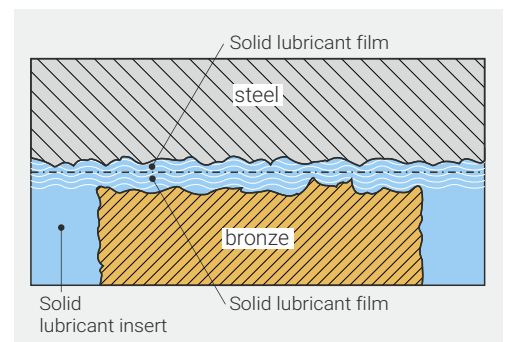

2.1 GGB-DB® SOLID LUBRICANTS

The special PTFE- or graphite-based solid lubricants used in GGB-DB® bearings have been extensively tested under laboratory conditions and proven in numerous successful applications.

The solid lubricant plugs are produced by a proprietary process which results in high density and lubricity, and are inserted into pockets in the bronze support. The distribution of these plugs in the bearing is critical to its performance. Designed to overlap in the sliding direction, they ensure optimum lubricant transfer to the mating surface. In addition there is no electrolytic or chemical reaction with the support or mating material, even when the bearings are subjected to high humidity or submerged in water.

2.2 RUNNING-IN FILM GGB-DB®

GGB-DB® bearings are supplied with a thin film of solid lubricant to facilitate the running-in process. It is applied after the lubricant plugs have been inserted and the surface has been finish machined.

The running-in film has a thickness of 15 µm to 20 µm and should not be removed. In the event of damage to the film during assembly, spray cans of lubricant can be used for on-site repair.

Some of the film is transferred to the mating surface with initial movement of the bearing. This is the start of a transition period which continues until the solid lubricant is released from the pockets. This material transfer provides:

- Constant low coefficient of friction
- Negligible stick-slip effect
- Immediate full load capacity

2.3 WEAR AND FRICTION PROPERTIES

The primary factors affecting the friction of GGB-DB® bearings are pressure, velocity, temperature and mating surface condition, with pressure being the most influential. Coefficient of friction and wear rates are subject to many factors. Under high loads and some humidity, for example, the value could be as low as 0.06; under lower loads and high temperatures it could reach 0.15. For GGB-DB® bearings calculations, assume a coefficient of friction of 0.15 to 0.17.

3 Technical Data

3.1 GGB-DB® STANDARD BRONZE ALLOYS*

GGB-DB® GRADE	ASTM		DIN		COMPOSITION		MECHANICAL PROPERTIES					APPLICATION
	Standard	Alloy No.	Standard	Alloy No.	ASTM % of weight	DIN % of weight	Density g/cm³	Minimum Tensile strength MPa [ksi]	Minimum Yield strength MPa [ksi]	Minimum Elong. % (in 50 mm)	Minimum Hardness HB	
GGB-DB®-B	B 584			2.1090.01	Cu 83	Cu 83						Standard material fulfills most application requirements
	B 271	C93200	1705	2.1090.03	Sn 7	Sn 7	8,85	207 [30]	97 [14]	15	75	
	B 505			2.1090.04	Pb 7	Pb 6,5						
				Zn 3	Zn 3,5							
GGB-DB®-C	B 584			2.0975.01	Cu 81	Cu 79,5						High load capacity with maximum corrosion resistance
	B 271	C95500	1714	2.0975.02	Ni 4	Ni 5	7,50	620 [90]	275 [40]	6	190	
	B 505			2.0975.03	Fe 4	Fe 4,75						
				2.0975.04	Al 11	Al 9,5						
GGB-DB®-D	B 584			2.0598.01	Cu 61	Cu 63,5						Highest load capacity, but less corrosion resistance than GGB-DB®-C
	B 271	C86300	1709	2.0598.02	Zn 27	Zn balance	7,70	758 [110]	414 [60]	12	210	
	B 505			2.0598.03	Fe 3	Fe 2,75						
					Al 6	Al 5						
				Mn 3	Mn 3,75							
GGB-DB®-E	For applications where standard GGB-DB® alloys are not suitable, we are able to supply special materials											

Table 2: GGB-DB® Standard Bronze Alloys

Maximum values depend on the chemical composition and the application engineering department should be consulted.

* The above shown figures are based on ASTM B271 (centrifugal casting) and intended for general information only. GGB application engineering team will make the appropriate selection based on your application data. The feasibility of some standard alloys depends upon the dimensional and geometric requirements of each project. Please contact GGB Applications Engineering for detailed information. Density depends on surrounding temperature and percentage of each alloy component in the material.

3.2 FITS AND TOLERANCES

Assembly involves pressing a GGB-DB® bearing with an interference fit between the outer diameter (D_o) and the housing bore (Figure 1), and between the inner ring and the shaft. Due to the high insertion forces that are required, super-cooling is recommended for bearings with $D_o > 200\text{mm}$.

Our application engineering team can provide a detailed procedure for this method.

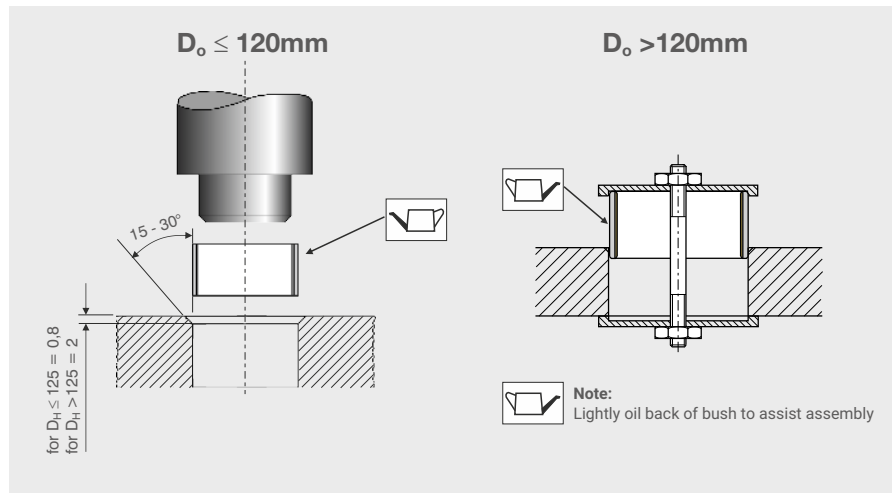

Figure 1: Fitting of Bearings

RECOMMENDED FITTING AND TOLERANCE RANGES

DIMENSION (FOR BEARING BORE $\leq 200\text{mm}$)	TOLERANCE	SURFACE FINISH (μm)
Housing bore	H7	3,2
Bush outer diameter	s6	3,2
Bearing bore (before assembly)	E8	1,2
Bearing bore (after assembly)	H10	1,2
Shaft diameter	d8	0,2 - 0,8
Concentricity bearing bore / bush outer diameter	IT9	

Table 3: Assembly data - cylindrical and flanged bearings

For bearing bores $> 200\text{mm}$, tolerances should be specified by our application engineering team based on the parameters of each application. Your specific application may require special fitting instructions.

3.3 MATING MATERIAL

The counterface material (shaft) must have appropriate characteristics, such as: hardness, surface finish and corrosion resistance. When a non standard GGB-DB® alloy is used, the hardness of the shaft should exceed that of the bronze by at least 100 HB.

4 GGB-DB® Design Factors

The main parameters for determining the size or calculating the service life of a GGB-DB® bearing include:

- Specific load limit p_{lim} [MPa]
- Temperature T [°C]
- pU factor [MPa x m/s]
- Other factors, e.g. design, housing material, lubrication, dirt and external influences
- Mating surface roughness R_a [μm]
- Mating surface material

4.1 SPECIFIC LOAD

The specific load p is defined as the working load divided by the projected area of the bearing and is expressed in MPa.

Bushes

$$(4.1.1) \quad p = \frac{F}{D_i \cdot B} \quad [\text{MPa}]$$

Slide Plates

$$(4.1.3) \quad p = \frac{F}{L \cdot W} \quad [\text{MPa}]$$

Thrust Washers

$$(4.1.2) \quad p = \frac{4F}{\pi \cdot (D_o^2 - D_i^2)} \quad [\text{MPa}]$$

Spherical Bearings

$$(4.1.4) \quad p = \frac{F}{d_k \cdot C} \quad [\text{MPa}]$$

4.2 SLIDING SPEED

The sliding speed U [m/s] is calculated as follows:

CONTINUOUS ROTATION

Bushes*

$$(4.2.1) \quad U = \frac{D_i \cdot \pi \cdot N}{60 \cdot 10^3} \quad [\text{MPa}]$$

Thrust Washers

$$(4.2.2) \quad U = \frac{\frac{D_o + D_i}{2} \cdot \pi \cdot N}{60 \cdot 10^3} \quad [\text{MPa}]$$

OSCILLATING MOVEMENT

Bushes*

$$(4.2.3) \quad U = \frac{D_i \cdot \pi}{60 \cdot 10^3} \cdot \frac{4\varphi \cdot N_{osz}}{360} \quad [\text{MPa}]$$

Thrust Washers

$$(4.2.4) \quad U = \frac{\frac{D_o + D_i}{2} \cdot \pi}{60 \cdot 10^3} \cdot \frac{4\varphi \cdot N_{osz}}{360} \quad [\text{MPa}]$$

*For GGB-DB spherical bearings sliding speed calculations, replace D_i by d_k .

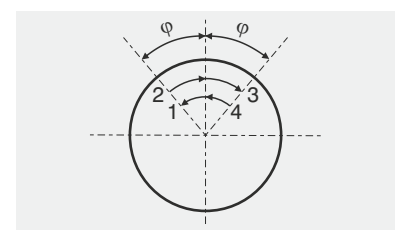

Figure 2: Oscillating cycle φ

4.3 pU FACTOR

The useful operating life of a GGB-DB® bearing is governed by the pv factor, which is calculated as follows:

$$(4.3.1) \quad pU = p \cdot U \quad [\text{MPa} \times \text{m/s}]$$

4.4 MATERIAL SELECTION

Material selection should be guided by GGB application engineers. For quick reference the following chart provides a generic interactive method of material selection:

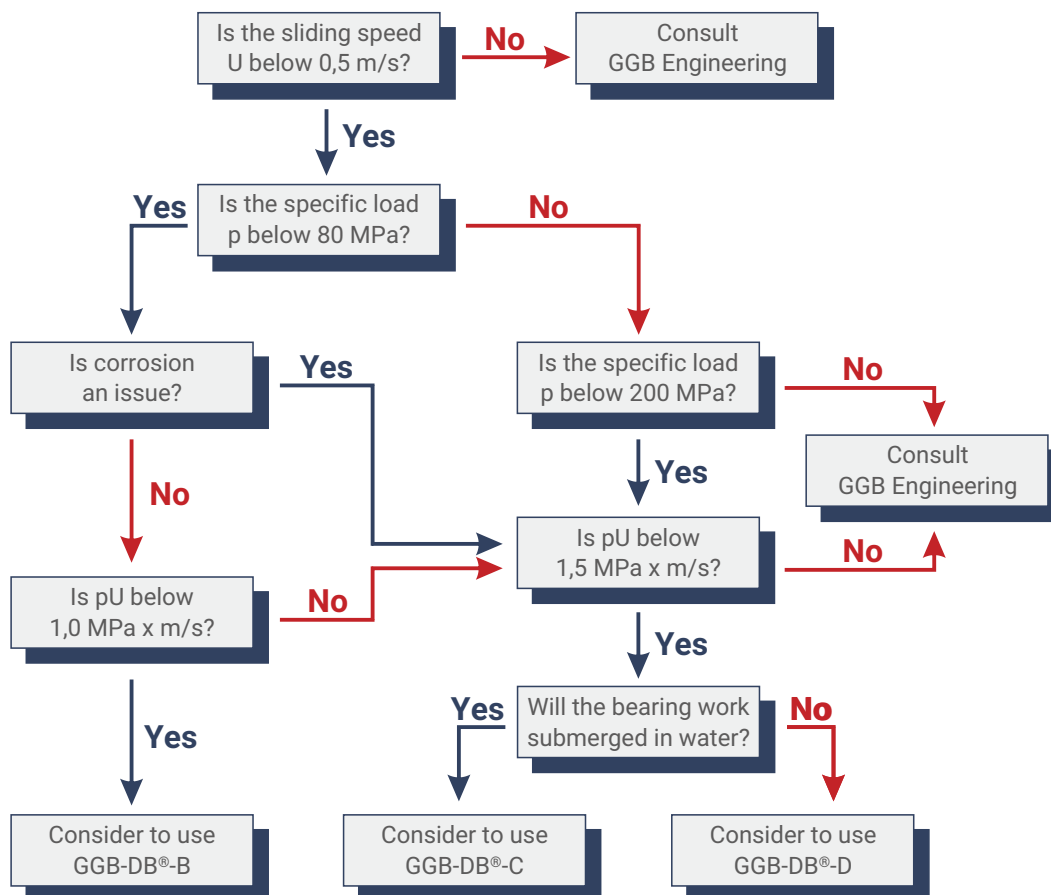

For working temperatures $\leq 180^\circ\text{C}$ consider white PTFE-based plugs; for working temperatures $> 180^\circ\text{C}$ consider black graphite-based plugs. Maximum working temperature depends upon the properties of the bronze alloy. Contact GGB Applications Engineering if your application temperature exceeds the limits of GGB-DB® standard alloys.

4.5 LIFETIME ESTIMATION

Estimated bearing life is useful in confirming the suitability of the bearing alloy selected for a particular application. On page 28 you will find a form for entering required data for bearing design calculation. Based on the data, our application engineers can estimate bearing life.

It is important to note that these calculations are based on the results of laboratory tests, simulating the conditions to which the bearing will be subjected. The effect of certain conditions, especially the presence of abrasive particles, cannot be fully reproduced in the laboratory. Therefore no lifetime warranties are given unless expressly declared in writing upon receipt of written confirmation of all application data.

TYPE OF LOAD

GGB-DB® bearings exhibit optimum performance under steady unidirectional loads, which reduce fatigue loads and effectively increase load capacity. This allows smaller bearings to be used and/or longer bearing life. Bearing performance under dynamic loads, which reduce load capacity, also depends upon fatigue resistance of the material.

SHAFT AND BEARING MOTION

GGB-DB® bearings perform best in a stationary position against a rotating or oscillating mating material. In this configuration the arc of contact increases with wear and the contact pressure decreases, extending bearing life. Conversely if the mating material is stationary, the opposite effect occurs; as wear proceeds, the arc of contact is reduced and contact pressure increases, shortening bearing life.

CORROSION

Corrosion resistance depends largely on the lubricant, bearing and mating surface materials. Graphite-based plugs should never be used where electrolytic corrosion can occur, such as high humidity atmospheres or submerged equipment. In this case PTFE-based plugs are recommended.

CHEMICAL PRODUCTS

GGB can provide guidance with regard to the chemical compatibility of GGB-DB bearings. It is recommended that chemical resistance be confirmed by testing whenever possible.

5 Forms and Dimensions

RADIAL BEARINGS

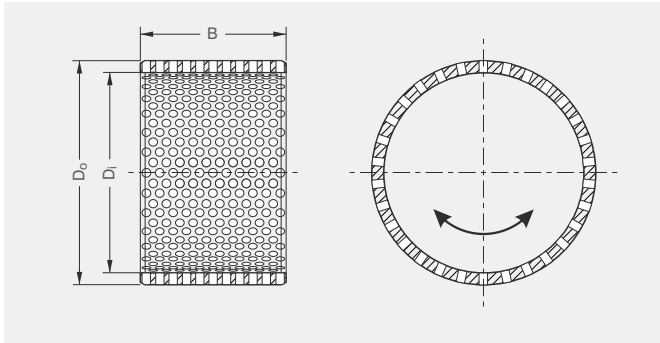

COMBINED RADIAL AND AXIAL BEARINGS

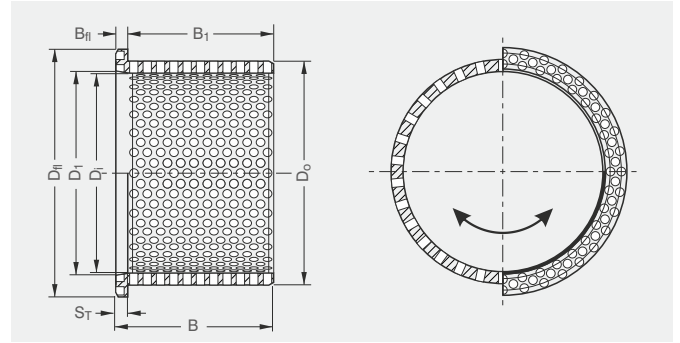

AXIAL BEARINGS / THRUST WASHERS

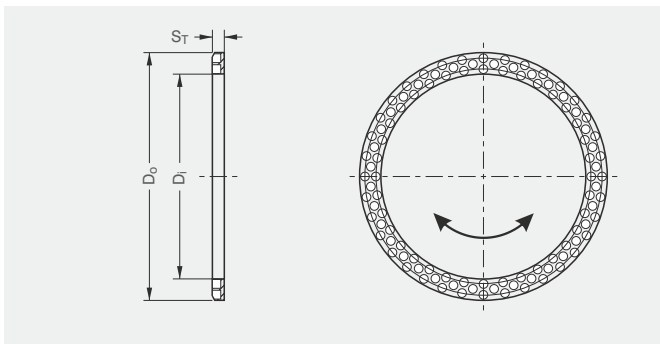

SLIDING PLATES

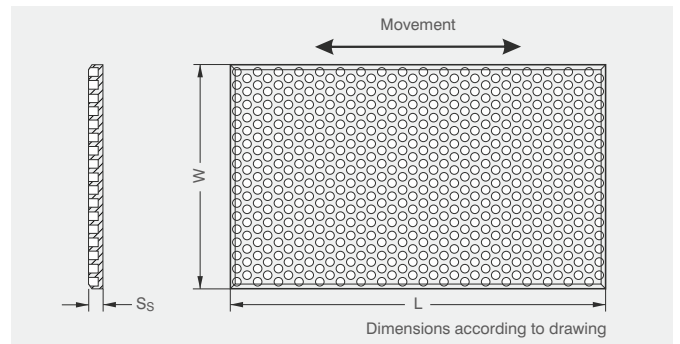

SPHERICAL BEARINGS

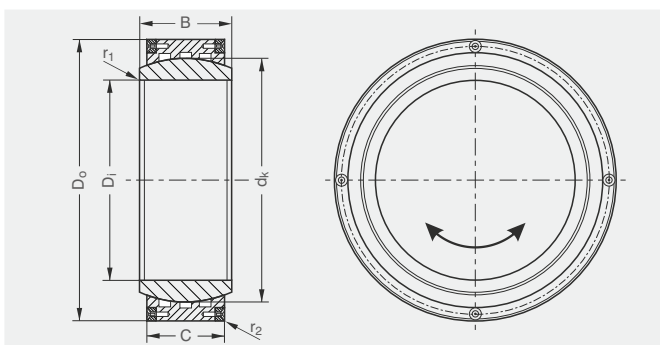

PINTLE BEARINGS

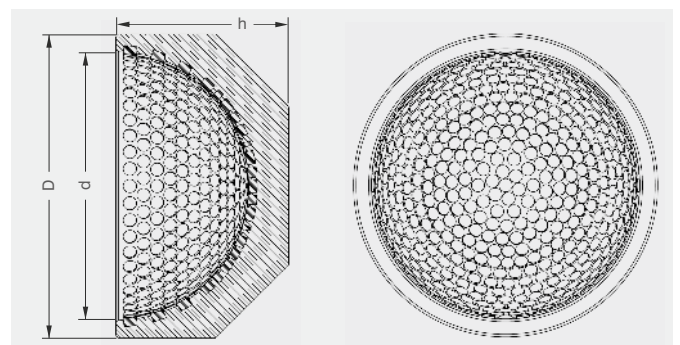

GGB-DB® bearings are made-to-order items. Custom-manufactured to specific requirements, they can readily be produced from drawings providing special dimensions and tolerances, and in forms not included in the following table such as axial and radial segments, half-shells and others. For reasons of economy, however, the types and sizes shown in the following tables should be used whenever possible.

Please contact GGB Applications Engineering for any other plug design distribution.

6 Installation

INSTALLATION OF GGB-DB® BEARINGS BY UNDERCOOLING

Preparation

GGB-DB® radial bearings of diameter greater than 200 mm are best installed by cooling. This technique allows easy assembly of interference fit without additional pressing tools or excessive forces and avoids any damage to the material. It is only permissible to undercool the bearing; heating up the housing is not advised.

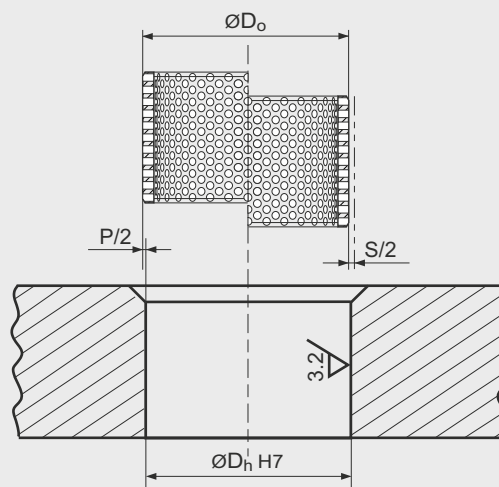

Fig.1: Press and shrinkage

Calculation of shrinkage

The shrinkage is calculated in accordance with DIN 7190. The values for ΔT depend on the cooling material used. To ensure a sufficient shrinkage a safety factor of 0.8 is applied (1.1).

(1.1) Shrinkage calculation

$$S = 0.8 \cdot \alpha \left[\frac{1}{K} \right] \cdot \Delta T [K] \cdot D_o [\text{mm}]$$

As the theoretical minimum temperatures might not be reached, especially for dry ice, a reduced ΔT value will be used for the calculation (1.2 - 1.4).

(1.2) Specific material values (Bronze)

$$\alpha_{Bz} \geq 18 \cdot 10^{-6} \left[\frac{1}{K} \right]$$

$$\Delta T_{CO_2} = 15 - (-65) = 80K$$

$$\Delta T_{IN_2} = 15 - (-195) = 210K$$

(1.3) Shrinkage with dry ice

$$S_{CO_2} = 0.8 \cdot 18 \cdot 10^{-6} \cdot 80 \cdot D_o [\text{mm}]$$

$$= 1.152 \cdot 10^{-3} \cdot D_o [\text{mm}]$$

(1.4) Shrinkage with liquid nitrogen

$$S_{IN_2} = 0.8 \cdot 18 \cdot 10^{-6} \cdot 210 \cdot D_o [\text{mm}]$$

$$= 3.024 \cdot 10^{-3} \cdot D_o [\text{mm}]$$

The use of dry ice is recommended for large bearing diameter above $\varnothing 250$ mm because of its ease of use and availability.

Before starting the undercooling process the bearing must be cleaned and dried. A closed wooden container insulated with expanded polystyrene is normally adequate for cooling (Fig. 2). To minimize the amount of dry ice required, it is advised to fill some of the space in the bore and edges with insulating material ensuring that any remaining space is large enough to be filled with the necessary quantity of dry ice. The dry ice should be finely crushed so that all bearing surfaces (including front faces) can be covered.

Depending on bearing size, the necessary cooling time may vary between 30 minutes and 2 hours (Fig.4).

The use of liquid nitrogen, especially for smaller bearings, offers a more effective cooling rate due to its lower temperature of -196 °C (Fig. 3 and 4). With liquid nitrogen the end of the cooling process is indicated when no more bubbles are evident (end of boiling).

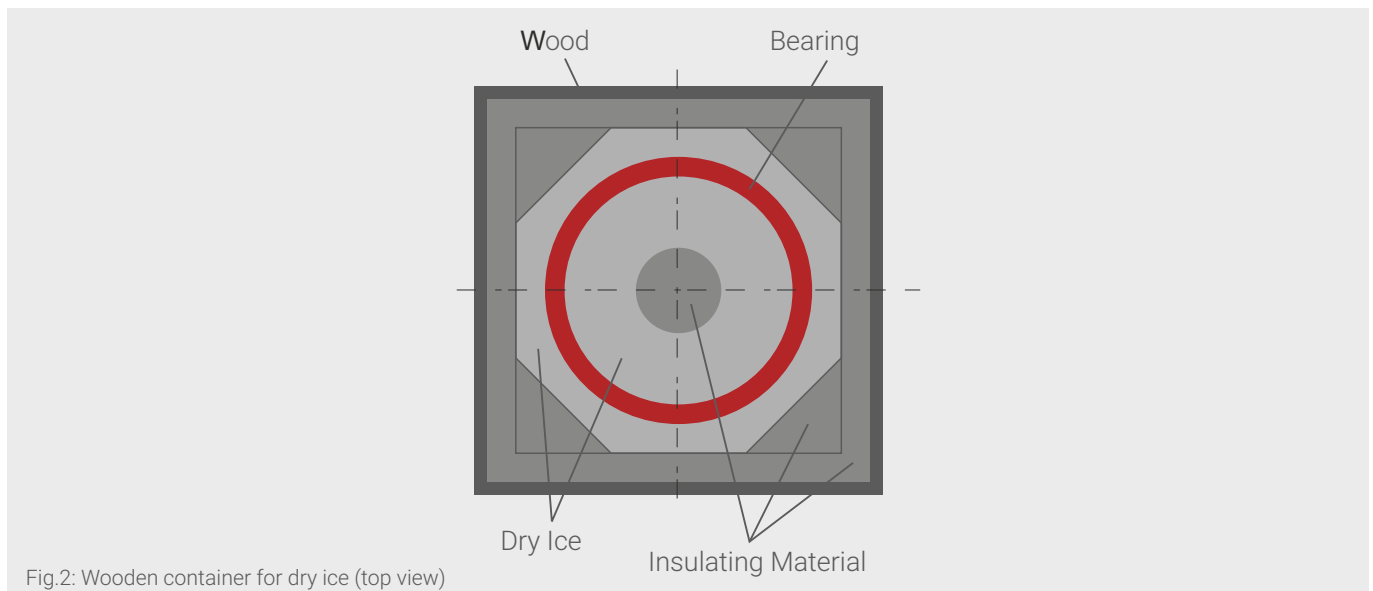

Special open insulation containers for handling liquid nitrogen are available at specialized trade suppliers and should be used.

The safety instructions regarding work with dry ice or liquid nitrogen must be adhered to.

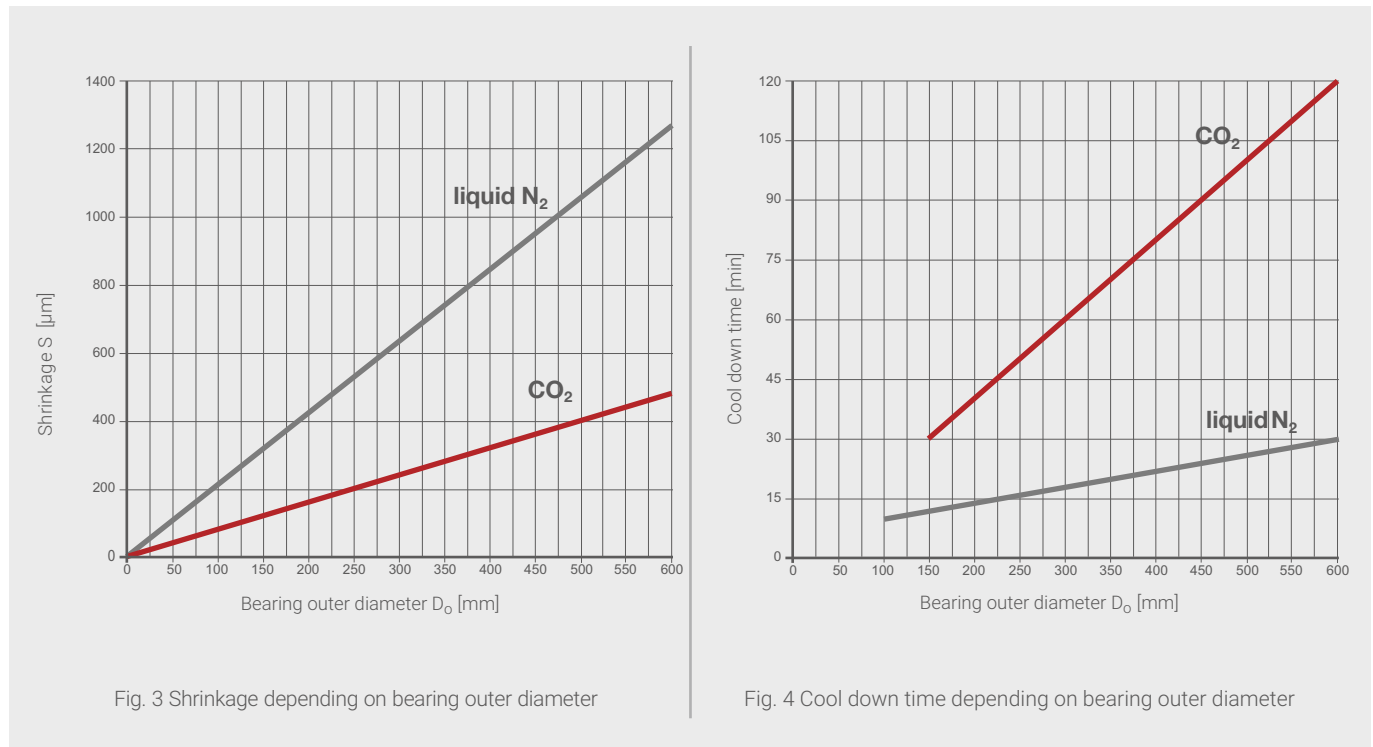

Before removing the bearing from the cooling medium, the effective shrinkage of the outer diameter should be measured. The measurement must be done quickly to avoid cooling down and shrinkage of the measuring equipment. When the necessary shrinkage of the bearing has been achieved, it must be installed without interruption. The installation should be possible without additional press in force. Bearing and housing bore should be cleaned carefully before installation. The housing bore may be slightly greased or oiled (recommended especially for smaller bearing dimension). In practice petroleum jelly has proved particularly effective.

7 Radial Bearings / Flanged Bearings/ Thrust Washers - Dimensions

RADIAL BEARINGS					FLANGED BEARINGS - THRUST WASHERS					
Diameter mm		Length B mm			Diameter mm				Flange thickn.	Length mm
D _i	D _o	1.0 x D _i	0.75 x D _i	1.25 x D _i	D _i	D ₁	D _o	D _{fl}	B _{fl} / S _T	B
10	15	10	7	13	10		15	20	2,5	
12	18	12	9	15	12		18	22	3,0	
14	20	14	10	18	14		20	25	3,0	
15	20	15	11	19	15		20	26	3,0	
16	22	16	12	20	16		22	28	3,0	
20	26	20	15	25	20		26	32	3,0	
22	28	22	16	28	22		28	34	3,0	
25	32	25	18	32	25		32	38	3,5	
28	35	28	21	35	28		35	42	3,5	
30	38	30	22	38	30		38	45	4,0	
35	44	35	26	44	35		44	50	4,5	
40	50	40	30	50	40		50	60	5,0	
45	55	45	33	56	45		55	70	5,0	
50	60	50	35	65	50		60	80	5,0	
55	65	55	40	70	55		65	85	5,0	
60	70	60	45	75	60		70	90	5,0	
65	76	65	45	80	65		76	95	5,5	
70	82	70	50	85	70		82	100	6,0	
75	88	75	55	90	75		88	105	6,5	
80	95	80	60	100	80		95	110	7,5	
85	100	85	60	105	85		100	115	7,5	
90	105	90	65	115	90		105	120	7,5	
95	110	95	70	120	95		110	130	7,5	
100	115	100	75	125	100		115	140	7,5	
110	125	110	80	140	110		125	150	7,5	
120	135	120	90	150	120		135	160	7,5	
140	160	140	100	175	140		160	180	10,0	
150	170	150	110	185	150		170	190	10,0	
180	200	180	135	225	180	185	200	230	10,0	
200	220	200	150	250	200	205	220	250	10,0	
225	250	225	170	280	225	230	250	275	12,5	
250	275	250	190	315	250	255	275	300	12,5	
280	310	280	210	350	280	285	310	340	15,0	
300	330	300	225	375	300	305	330	360	15,0	
350	380	350	260	435	350	355	380	420	15,0	
400	435	400	300	500	400	405	435	480	17,5	
450	490	450	340	560	450	455	490	530	20,0	
500	540	500	375	625	500	510	540	600	20,0	
550	590	550	415	690	550	560	590	650	20,0	
600	640	600	450	750*	600	610	640	720	20,0	
650	700	650	490	815*	650	660	700	780	25,0	
700	750	700	525	875*	700	710	750	840	25,0	
750	800	750*	560	940*	750	760	800	900	25,0	
800	850	800*	600	1000*	800	810	850	960	25,0	
850	900	850*	640	1060*	850	860	900	1020	25,0	
900	950	900*	675	1125*	900	910	950	1080	25,0	
950	1000	950*	710*	1200*	950	960	1000	1140	25,0	
1000	1060	1000*	750*	1250*	1000	1010	1060	1200	30,0	
1200	1260	1200*	900*	1500*	1200	1210	1260	1440	30,0	

Flanged bearing
B_{fl} / S_T = flange or washer thickness

Cylindrical bearing and thrust washer
Length B = B₁ + B_{fl} / S_T where B₁ = bearing length and

* Splitted in length (2 x 0.5) for technical reasons

8 Spherical Bearings - Standard C Series

Dimensions and Load Capacity

ISO 12240-1 C Series									GGB-DB®-B				GGB-DB®-C			
D _i	D _o	B	C	d ₁	d _k	r ₁	r ₂	α	Radial [kN]		Axial [kN]		Radial [kN]		Axial [kN]	
									dynamic	static	dynamic	static	dynamic	static	dynamic	static
320	440	160	135	340	375	1,1	3	4	3.680	6.130	1.040	1.730	10.810	18.020	3.050	5.090
340	460	160	135	360	390	1,1	3	3	3.820	6.380	1.040	1.730	11.240	18.740	3.050	5.090
360	480	160	135	380	410	1,1	3	3	4.020	6.700	1.040	1.730	11.820	19.700	3.050	5.090
380	520	190	160	400	440	1,5	4	4	5.120	8.530	1.460	2.430	15.040	25.060	4.290	7.150
400	540	190	160	425	465	1,5	4	3	5.410	9.010	1.460	2.430	15.890	26.490	4.290	7.150
420	560	190	160	445	480	1,5	4	3	5.580	9.300	1.460	2.430	16.400	27.340	4.290	7.150
440	600	218	185	465	515	1,5	4	3	6.920	11.540	1.950	3.250	20.350	33.920	5.740	9.570
460	620	218	185	485	530	1,5	4	3	7.130	11.880	1.950	3.250	20.940	34.910	5.740	9.570
480	650	230	195	510	560	2	5	3	7.940	13.230	2.170	3.610	23.320	38.880	6.380	10.630
500	670	230	195	530	580	2	5	3	8.220	13.700	2.170	3.610	24.160	40.270	6.380	10.630
530	710	243	205	560	610	2	5	3	9.090	15.150	2.400	4.000	26.710	44.520	7.050	11.750
560	750	258	215	590	645	2	5	4	10.080	16.800	2.640	4.400	29.620	49.370	7.750	12.920
600	800	272	230	635	690	2	5	3	11.540	19.230	3.020	5.030	33.900	56.500	8.870	14.790
630	850	300	260	665	730	3	6	3	13.800	23.000	3.860	6.430	40.540	67.580	11.340	18.900
670	900	308	260	710	800	3	6	3	15.120	25.210	3.860	6.430	44.430	74.060	11.340	18.900
710	950	325	275	755	820	3	6	3	16.400	27.330	4.310	7.190	48.170	80.290	12.680	21.140
750	1000	335	280	800	870	3	6	3	17.710	29.520	4.470	7.460	52.040	86.730	13.150	21.920
800	1060	355	300	850	915	3	6	3	19.960	33.270	5.140	8.560	58.640	97.730	15.100	25.160
850	1120	365	310	905	975	3	6	3	21.980	36.630	5.480	9.140	64.570	107.610	16.120	26.870
900	1180	375	320	960	1030	3	6	3	23.970	39.950	5.840	9.740	70.410	117.350	17.180	28.630
950	1250	400	340	1015	1090	4	7,5	3	26.950	44.920	6.600	11.000	79.170	131.950	19.390	32.320
1000	1320	438	370	1065	1150	4	7,5	3	30.940	51.570	7.810	13.030	90.900	151.500	22.970	38.280
1060	1400	462	390	1130	1220	4	7,5	3	34.600	57.670	8.680	14.470	101.640	169.410	25.520	42.530
1120	1460	462	390	1195	1280	4	7,5	3	36.300	60.500	8.680	14.470	106.640	177.740	25.520	42.530
1180	1540	488	410	1260	1350	4	7,5	3	40.250	67.090	9.600	16.000	118.240	197.070	28.200	47.000
1250	1630	515	435	1330	1425	4	7,5	3	45.080	75.130	10.800	18.010	132.420	220.710	31.740	52.910
1320	1720	545	460	1405	1510	4	7,5	3	50.510	84.190	12.080	20.140	148.390	247.310	35.500	59.170
1400	1820	585	495	1485	1600	5	9,5	3	57.600	96.000	13.990	23.320	169.200	282.000	41.110	68.520
1500	1950	625	530	1590	1710	5	9,5	3	65.910	109.850	16.040	26.740	193.610	322.690	47.130	78.550
1600	2060	670	565	1690	1820	5	9,5	3	74.780	124.640	18.230	30.390	219.680	366.130	53.560	89.270
1700	2180	710	600	1790	1925	5	9,5	3	84.000	140.000	20.560	34.270	246.750	411.250	60.400	100.670
1800	2300	750	635	1890	2035	6	12	3	93.980	156.630	23.030	38.380	276.060	460.110	67.650	112.760
1900	2430	790	670	2000	2150	6	12	3	104.760	174.600	25.640	42.730	307.740	512.900	75.320	125.530
2000	2570	935	705	2100	2260	6	12	3	115.870	193.120	28.390	47.310	340.380	567.310	83.390	138.990

ISO 12240-1 C Series									GGB-DB®-D			
D _i	D _o	B	C	d ₁	d _k	r ₁	r ₂	α	Radial [kN]		Axial [kN]	
									dynamic	static	dynamic	static
320	440	160	135	340	375	1,1	3	4	13.110	21.860	3.700	6.180
340	460	160	135	360	390	1,1	3	3	13.640	22.730	3.700	6.180
360	480	160	135	380	410	1,1	3	3	14.340	23.900	3.700	6.180
380	520	190	160	400	440	1,5	4	4	18.240	30.400	5.200	8.680
400	560	190	160	425	465	1,5	4	3	19.270	32.120	5.200	8.680
420	560	190	160	445	480	1,5	4	3	19.890	33.160	5.200	8.680
440	600	218	185	465	515	1,5	4	3	24.680	41.140	6.960	11.600
460	620	218	185	485	530	1,5	4	3	25.400	42.330	6.960	11.600
480	650	230	195	510	560	2	5	3	28.290	47.150	7.730	12.890
500	670	230	195	530	580	2	5	3	29.300	48.830	7.730	12.890
530	710	243	205	560	610	2	5	3	32.390	53.990	8.550	14.250
560	750	258	215	590	645	2	5	4	35.920	59.880	9.400	15.670
600	800	272	230	635	690	2	5	3	41.110	68.520	10.760	17.940
630	850	300	260	665	730	3	6	3	49.170	81.950	13.750	22.920
670	900	308	260	710	800	3	6	3	53.890	89.810	13.750	22.920
710	950	325	275	755	820	3	6	3	58.420	97.370	15.380	25.640
750	1000	335	280	800	870	3	6	3	63.110	105.190	15.950	26.580
800	1060	355	300	850	915	3	6	3	71.120	118.530	18.310	30.520
850	1120	365	310	905	975	3	6	3	78.310	130.510	19.550	32.590
900	1180	375	320	960	1030	3	6	3	85.390	142.320	20.830	34.720
950	1250	400	340	1015	1090	4	7,5	3	96.010	160.030	23.520	39.200
1000	1320	438	370	1065	1150	4	7,5	3	110.240	183.730	27.850	46.420
1060	1400	462	390	1130	1220	4	7,5	3	123.270	205.450	30.950	51.580
1120	1460	462	390	1195	1280	4	7,5	3	129.330	215.560	30.950	51.580
1180	1540	488	410	1260	1350	4	7,5	3	143.400	239.010	34.200	57.010
1250	1630	515	435	1330	1425	4	7,5	3	160.600	267.670	38.500	64.170
1320	1720	545	460	1405	1510	4	7,5	3	179.960	299.940	43.050	71.760
1400	1820	585	495	1485	1600	5	9,5	3	205.200	342.000	49.860	83.100
1500	1950	625	530	1590	1710	5	9,5	3	234.810	391.350	57.160	95.260
1600	2060	670	565	1690	1820	5	9,5	3	266.420	444.030	64.950	108.260
1700	2180	710	600	1790	1925	5	9,5	3	299.250	498.750	73.250	122.090
1800	2300	750	635	1890	2035	6	12	3	334.800	558.000	82.050	136.750
1900	2430	790	670	2000	2150	6	12	3	373.220	622.030	91.340	152.240
2000	2570	935	705	2100	2260	6	12	3	412.800	688.010	101.130	168.560

Notes:

1. Load capacity indicated above is intended for preliminary orientation. It is recommended that our application team evaluates each project.
2. The loads indicated above are the maximum limits under very low sliding speeds.
3. Standard spherical bearing sizes per ISO 12240-1; Sizes can also be determined based on specific application operational data. All spherical bearings are manufactured on customer request and are not available ex-stock.

9 Spherical Bearings - Standard E Series

Dimensions and Load Capacity

ISO 12240-1 E Series									GGB-DB®-B				GGB-DB®-C			
D _i	D _o	B	C	d ₁	d _k	r ₁	r ₂	α	Radial [kN]		Axial [kN]		Radial [kN]		Axial [kN]	
									dynamic	static	dynamic	static	dynamic	static	dynamic	static
50	75	35	28	55	66	0,6	1	7	130	220	40	70	390	650	130	210
55	85	40	32	62	74	0,6	1	7	170	280	50	90	500	840	170	280
60	90	44	36	66	80	1	1	6	200	340	70	120	610	1.020	210	360
70	105	49	40	77	92	1	1	6	260	440	90	150	780	1.310	260	440
80	120	55	45	88	105	1	1	6	340	570	110	190	1.000	1.680	330	560
90	130	60	50	98	115	1	1	5	410	690	140	230	1.220	2.040	410	690
100	150	70	55	109	130	1	1	7	520	860	170	280	1.520	2.540	500	840
110	160	70	55	120	140	1	1	6	560	930	170	280	1.640	2.740	500	840
120	180	85	70	130	160	1	1	6	810	1.350	270	460	2.390	3.980	820	1.370
140	210	90	70	150	180	1	1	7	910	1.520	270	460	2.690	4.480	820	1.370
160	230	105	80	170	200	1	1	8	1.160	1.930	360	600	3.410	5.690	1.070	1.780
180	260	105	80	192	225	1,1	1,1	6	1.300	2.180	360	600	3.840	6.400	1.070	1.780
200	290	130	100	212	250	1,1	1,1	7	1.810	3.030	570	950	5.340	8.900	1.670	2.790
220	320	135	100	238	275	1,1	1,1	8	2.000	3.330	570	950	5.870	9.790	1.670	2.790
240	340	140	100	265	300	1,1	1,1	8	2.180	3.630	570	950	6.400	10.680	1.670	2.790
260	370	150	110	285	325	1,1	1,1	7	2.600	4.330	690	1.150	7.630	12.720	2.030	3.380
280	400	155	120	310	350	1,1	1,1	6	3.050	5.090	820	1.370	8.970	14.950	2.410	4.020
300	430	165	120	330	375	1,1	1,1	7	3.270	5.450	820	1.370	9.610	16.020	2.410	4.020

ISO 12240-1 E Series									GGB-DB®-D			
D _i	D _o	B	C	d ₁	d _k	r ₁	r ₂	α	Radial [kN]		Axial [kN]	
									dynamic	static	dynamic	static
50	75	35	28	55	66	0,6	1	7	470	790	150	260
55	85	40	32	62	74	0,6	1	7	610	1.020	200	340
60	90	44	36	66	80	1	1	6	740	1.240	260	430
70	105	49	40	77	92	1	1	6	950	1.580	320	540
80	120	55	45	88	105	1	1	6	1.220	2.040	410	680
90	130	60	50	98	115	1	1	5	1.480	2.480	500	840
100	150	70	55	109	130	1	1	7	1.850	3.080	610	1.020
110	160	70	55	120	140	1	1	6	1.990	3.320	610	1.020
120	180	85	70	130	160	1	1	6	2.900	4.830	990	1.660
140	210	90	70	150	180	1	1	7	3.260	5.440	990	1.660
160	230	105	80	170	200	1	1	8	4.140	6.900	1.300	2.170
180	260	105	80	192	225	1,1	1,1	6	4.660	7.770	1.300	2.170
200	290	130	100	212	250	1,1	1,1	7	6.470	10.790	2.030	3.390
220	320	135	100	238	275	1,1	1,1	8	7.120	11.870	2.030	3.390
240	340	140	100	265	300	1,1	1,1	8	7.770	12.950	2.030	3.390
260	370	150	110	285	325	1,1	1,1	7	9.260	15.430	2.460	4.100
280	400	155	120	310	350	1,1	1,1	6	10.880	18.130	2.930	4.880
300	430	165	120	330	375	1,1	1,1	7	11.650	19.430	2.930	4.880

Notes:

1. Load capacity indicated above is intended for preliminary orientation. It is recommended that our application team evaluates each project.
2. The loads indicated above are the maximum limits under very low sliding speeds.
3. Standard spherical bearing sizes per ISO 12240-1; Sizes can also be determined based on specific application operational data. All spherical bearings are manufactured on customer request and are not available ex-stock.

10 Spherical Bearings - Standard G Series

Dimensions and Load Capacity

ISO 12240-1 G Series									GGB-DB®-B				GGB-DB®-C			
D _i	D _o	B	C	d ₁	d _k	r ₁	r ₂	α	Radial [kN]		Axial [kN]		Radial [kN]		Axial [kN]	
									dynamic	static	dynamic	static	dynamic	static	dynamic	static
50	90	56	36	57	80	0,6	1	17	200	340	70	120	610	1.020	210	360
60	105	63	40	67	92	1	1	17	260	440	90	150	780	1.310	260	440
70	120	70	45	77	105	1	1	16	340	570	110	190	1.000	1.680	330	560
80	130	75	50	87	115	1	1	15	410	690	140	230	1.220	2.040	410	690
90	150	85	55	98	130	1	1	14	520	860	170	280	1.520	2.540	500	840
100	160	85	55	110	140	1	1	14	560	930	170	280	1.640	2.740	500	840
110	180	100	70	122	160	1	1	12	810	1.350	270	460	2.390	3.980	820	1.370
120	210	115	70	132	180	1	1	16	910	1.520	270	460	2.690	4.480	820	1.370
140	230	130	80	151	200	1	1	16	1.160	1.930	360	600	3.410	5.690	1.070	1.780
160	260	135	80	176	225	1	1,1	16	1.300	2.180	360	600	3.840	6.400	1.070	1.780
180	290	155	100	196	250	1,1	1,1	14	1.810	3.030	570	950	5.340	8.900	1.670	2.790
200	320	165	100	220	275	1,1	1,1	15	2.000	3.330	570	950	5.870	9.790	1.670	2.790
220	340	175	100	243	300	1,1	1,1	16	2.180	3.630	570	950	6.400	10.680	1.670	2.790
240	370	190	110	263	325	1,1	1,1	15	2.600	4.330	690	1.150	7.630	12.720	2.030	3.380
260	400	205	120	283	350	1,1	1,1	15	3.050	5.090	820	1.370	8.970	14.950	2.410	4.020
280	430	210	120	310	375	1,1	1,1	15	3.270	5.450	820	1.370	9.610	16.020	2.410	4.020

ISO 12240-1 G Series									GGB-DB®-D			
D _i	D _o	B	C	d ₁	d _k	r ₁	r ₂	α	Radial [kN]		Axial [kN]	
									dynamic	static	dynamic	static
50	90	56	36	57	80	0,6	1	17	740	1.240	260	430
60	105	63	40	67	92	1	1	17	950	1.580	320	540
70	120	70	45	77	105	1	1	16	1.220	2.040	410	680
80	130	75	50	87	115	1	1	15	1.480	2.480	500	840
90	150	85	55	98	130	1	1	14	1.850	3.080	610	1.020
100	160	85	55	110	140	1	1	14	1.990	3.320	610	1.020
110	180	100	70	122	160	1	1	12	2.900	4.830	990	1.660
120	210	115	70	132	180	1	1	16	3.260	5.440	990	1.660
140	230	130	80	151	200	1	1	16	4.140	6.900	1.300	2.170
160	260	135	80	176	225	1	1,1	16	4.660	7.770	1.300	2.170
180	290	155	100	196	250	1,1	1,1	14	6.470	10.790	2.030	3.390
200	320	165	100	220	275	1,1	1,1	15	7.120	11.870	2.030	3.390
220	340	175	100	243	300	1,1	1,1	16	7.770	12.950	2.030	3.390
240	370	190	110	263	325	1,1	1,1	15	9.260	15.430	2.460	4.100
260	400	205	120	283	350	1,1	1,1	15	10.880	18.130	2.930	4.880
280	430	210	120	310	375	1,1	1,1	15	11.650	19.430	2.930	4.880

Notes:

1. Load capacity indicated on pages 24/25 is intended for preliminary orientation. It is recommended that our application team evaluates each project.
2. The loads indicated above are the maximum limits under very low sliding speeds.
3. Standard spherical bearing sizes per ISO 12240-1; Sizes can also be determined based on specific application operational data.
All spherical bearings are manufactured on customer request and are not available ex-stock.

11 Spherical Bearings - Standard H Series Dimensions and Load Capacity

ISO 12240-1 H Series									GGB-DB®-B				GGB-DB®-C			
D _i	D _o	B	C	d ₁	d _k	r ₁	r ₂	α	Radial [kN]		Axial [kN]		Radial [kN]		Axial [kN]	
									dynamic	static	dynamic	static	dynamic	static	dynamic	static
100	150	71	67	114	135	1	1	2	650	1.090	250	420	1.930	3.220	750	1.250
110	160	78	74	122	145	1	1	2	780	1.300	310	520	2.290	3.820	910	1.530
120	180	85	80	135	180	1	1	2	1.040	1.740	360	600	3.070	5.120	1.070	1.780
140	210	100	95	155	185	1	1	2	1.270	2.130	510	850	3.750	6.250	1.510	2.520
160	230	115	109	175	210	1	1	2	1.660	2.770	670	1.130	4.890	8.150	1.990	3.320
180	260	128	122	203	240	1,1	1,1	2	2.120	3.540	850	1.410	6.250	10.420	2.490	4.160
200	290	140	134	219	260	1,1	1,1	2	2.530	4.220	1.020	1.700	7.440	12.400	3.010	5.020
220	320	155	148	245	290	1,1	1,1	2	3.120	5.200	1.250	2.080	9.160	15.280	3.670	6.120
240	340	170	162	259	310	1,1	1,1	2	3.650	6.080	1.490	2.490	10.720	17.880	4.400	7.330
260	370	185	175	285	340	1,1	1,1	2	4.320	7.210	1.740	2.910	12.710	21.180	5.130	8.560
280	400	200	190	311	370	1,1	1,1	2	5.110	8.520	2.060	3.430	15.010	25.030	6.050	10.090
300	430	212	200	327	390	1,1	1,1	2	5.670	9.450	2.280	3.800	16.660	27.770	6.710	11.180
320	460	230	218	344	414	1,1	3	2	6.560	10.930	2.710	4.520	19.280	32.130	7.970	13.290
340	480	243	230	359	434	1,1	3	2	7.250	12.090	3.020	5.030	21.320	35.540	8.870	14.790
360	520	258	243	397	474	1,1	4	2	8.370	13.960	3.370	5.620	24.600	41.010	9.900	16.510
380	540	272	258	412	494	1,5	4	2	9.260	15.440	3.800	6.330	27.220	45.380	11.160	18.610
400	580	280	265	431	514	1,5	4	2	9.900	16.510	4.010	6.680	29.090	48.490	11.780	19.630
420	600	300	280	441	534	1,5	4	2	10.870	18.120	4.470	7.460	31.940	53.230	13.150	21.920
440	630	315	300	479	574	1,5	4	2	12.520	20.870	5.140	8.560	36.780	61.310	15.100	25.160
460	650	325	308	496	593	1,5	5	2	13.280	22.130	5.410	9.030	39.010	65.030	15.910	26.520
480	680	340	320	522	623	2	5	2	14.490	24.160	5.840	9.740	42.590	70.980	17.180	28.630
500	710	355	335	536	643	2	5	2	15.660	26.100	6.410	10.680	46.010	76.690	18.830	31.380
530	750	375	355	558	673	2	5	2	17.370	28.950	7.190	11.990	51.040	85.060	21.140	35.240
560	800	400	380	602	723	2	5	2	19.980	33.300	8.240	13.740	58.690	97.820	24.220	40.380
600	850	425	400	645	773	2	6	2	22.480	37.470	9.130	15.230	66.050	110.090	26.840	44.740
630	900	450	425	677	813	3	6	2	25.120	41.880	10.310	17.190	73.810	123.020	30.300	50.510
670	950	475	450	719	862	3	6	2	28.210	47.010	11.560	19.270	82.860	138.110	33.970	56.620
710	1000	500	475	762	912	3	6	2	31.500	52.500	12.880	21.470	92.540	154.240	37.850	63.090
750	1060	530	500	814	972	3	6	2	35.340	58.900	14.270	23.790	103.820	173.040	41.940	69.910
800	1120	565	530	851	1022	3	6	2	39.390	65.650	16.040	26.740	115.710	192.860	47.130	78.550
850	1220	600	565	936	1112	3	7,5	2	45.690	76.150	18.230	30.390	134.220	223.700	53.560	89.270
900	1250	635	600	949	1142	3	7,5	2	49.830	83.050	20.560	34.270	146.380	243.970	60.400	100.670
950	1360	670	635	1045	1242	4	7,5	2	57.350	95.590	23.030	38.380	168.480	280.810	67.650	112.760
1000	1450	710	670	1103	1312	4	7,5	2	63.930	106.550	25.640	42.730	187.790	312.990	75.320	125.530

ISO 12240-1 H Series									GGB-DB®-D			
D _i	D _o	B	C	d ₁	d _k	r ₁	r ₂	α	Radial [kN]		Axial [kN]	
									dynamic	static	dynamic	static
100	150	71	67	114	135	1	1	2	2.340	3.900	910	1.520
110	160	78	74	122	145	1	1	2	2.780	4.630	1.110	1.850
120	180	85	80	135	180	1	1	2	3.730	6.210	1.300	2.170
140	210	100	95	155	185	1	1	2	4.550	7.580	1.830	3.060
160	230	115	109	175	210	1	1	2	5.930	9.880	2.410	4.020
180	260	128	122	203	240	1,1	1,1	2	7.580	12.640	3.020	5.040
200	290	140	134	219	260	1,1	1,1	2	9.020	15.040	3.650	6.080
220	320	155	148	245	290	1,1	1,1	2	11.120	18.530	4.450	7.420
240	340	170	162	259	310	1,1	1,1	2	13.010	21.680	5.340	8.900
260	370	185	175	285	340	1,1	1,1	2	15.410	25.690	6.230	10.380
280	400	200	190	311	370	1,1	1,1	2	18.210	30.350	7.340	12.240
300	430	212	200	327	390	1,1	1,1	2	20.200	33.680	8.130	13.560
320	460	230	218	344	414	1,1	3	2	23.380	38.970	9.670	16.110
340	480	243	230	359	434	1,1	3	2	25.860	43.100	10.760	17.940
360	520	258	243	397	474	1,1	4	2	29.840	49.730	12.010	20.020
380	540	272	258	412	494	1,5	4	2	33.020	55.030	13.540	22.570
400	580	280	265	431	514	1,5	4	2	35.290	58.810	14.290	23.810
420	600	300	280	441	534	1,5	4	2	38.730	64.560	15.950	26.580
440	630	315	300	479	574	1,5	4	2	44.610	74.350	18.310	30.520
460	650	325	308	496	593	1,5	5	2	47.320	78.860	19.300	32.170
480	680	340	320	522	623	2	5	2	51.650	86.080	20.830	34.720
500	710	355	335	536	643	2	5	2	55.800	93.010	22.830	38.060
530	750	375	355	558	673	2	5	2	61.900	103.160	25.640	42.740
560	800	400	380	602	723	2	5	2	71.180	118.630	29.380	48.970
600	850	425	400	645	773	2	6	2	80.110	133.510	32.550	54.260
630	900	450	425	677	813	3	6	2	89.520	149.200	36.750	61.250
670	950	475	450	719	862	3	6	2	100.500	167.500	41.200	68.670
710	1000	500	475	762	912	3	6	2	112.230	187.060	45.910	76.520
750	1060	530	500	814	972	3	6	2	125.910	209.860	50.870	84.780
800	1120	565	530	851	1022	3	6	2	140.330	233.890	57.160	95.260
850	1220	600	565	936	1112	3	7,5	2	162.780	271.300	64.950	108.260
900	1250	635	600	949	1142	3	7,5	2	177.520	295.880	73.250	122.090
950	1360	670	635	1045	1242	4	7,5	2	204.330	340.560	82.050	136.750
1000	1450	710	670	1103	1312	4	7,5	2	227.750	379.580	91.340	152.240

Notes:

1. Load capacity indicated above is intended for preliminary orientation. It is recommended that our application team evaluates each project.
2. The loads indicated above are the maximum limits under very low sliding speeds.
3. Standard spherical bearing sizes per ISO 12240-1; Sizes can also be determined based on specific application operational data. All spherical bearings are manufactured on customer request and are not available ex-stock.

Bearing Application Data Sheet

Not sure which GGB part fits your application requirements? Go to www.ggbpartfinder.com to complete a Bearing Application Data Sheet online, and one of our GGB bearing specialists will reach out to you with recommended options that meet your application requirements. You can also complete the form below and share it with your GGB sales person or distributor representative.

DATA FOR BEARING DESIGN CALCULATION

Application: _____

Project/No.: _____ Quantity: _____

New Design Existing Design

DIMENSIONS (MM)

Inside diameter	D_i	
Outside diameter	D_o	
Length	B	
Flange Diameter	D_{fl}	
Flange thickness	B_{fl}	
Wall thickness	S_T	
Length of slideplate	L	
Width of slideplate	W	
Thickness of slideplate	S_s	

LOAD

Radial load F	static [N] dynamic [N]	
Axial load F	static [N] dynamic [N]	
Specific load F	static [N] dynamic [N]	

MOVEMENT

Rotational speed	N [1/min]	
Speed	U [m/s]	
Length of stroke	L_s [mm]	
Frequency of stroke	[1/min]	
Oscillating cycle	ϕ [°]	
Osc. frequency	N_{osz} [1/min]	

MATING SURFACE

Material		
Hardness	HB/HRC	
Surface finish	Ra [µm]	

CUSTOMER INFORMATION

Company _____
 Street _____
 City / State / Province / Post Code _____
 Telephone _____ Fax _____
 Name _____
 Email Address _____ Date _____

FITS & TOLERANCES

Shaft	D_J	
Bearing housing	D_H	

OPERATING ENVIRONMENT

Ambient temperature	T_{amb} [°]	
<input type="checkbox"/> Housing with good heating transfer properties		
<input type="checkbox"/> Light pressing or insulated housing with poor heat transfer properties		
<input type="checkbox"/> Non metal housing with poor heat transfer properties		
<input type="checkbox"/> Alternate operation in water and dry		

LUBRICATION

<input type="checkbox"/> Dry		
<input type="checkbox"/> Continuous lubrication		
<input type="checkbox"/> Process fluid lubrication		
<input type="checkbox"/> Initial lubrication only		
<input type="checkbox"/> Hydrodynamic conditions		
Process fluid		
Lubricant		
Dynamic viscosity	η	

SERVICE HOURS PER DAY

Continuous operation		
Intermittent operation		
Operating time		
Days per year		

SERVICE LIFE

Required service life	L_H [h]	
-----------------------	-----------	--

BEARING TYPE

Cylindrical

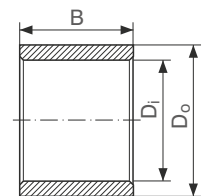

Flanged bush

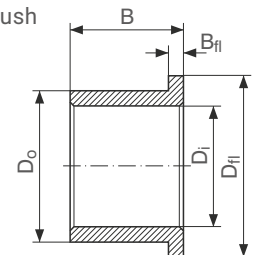

Thrust washer

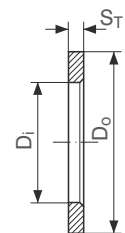

Slideplate

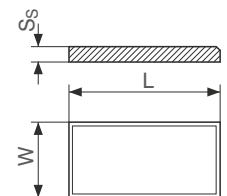

- Special parts (sketch) Rotating load
 Rotational movement Oscillating movement
 Steady load Linear movement

Product Information

GGB gives an assurance that the products described in this document have no manufacturing errors or material deficiencies.

The details set out in this document are registered to assist in assessing the material's suitability for the intended use. They have been developed from our own investigations as well as from generally accessible publications. They do not represent any assurance for the properties themselves.

Unless expressly declared in writing, GGB gives no warranty that the products described are suited to any particular purpose or specific operating circumstances. GGB accepts no liability for any losses, damages or costs however they may arise through direct or indirect use of these products.

GGB's sales and delivery terms and conditions, included as an integral part of quotations, stock and price lists, apply absolutely to all business conducted by GGB. Copies can be made available on request.

Products are subject to continual development. GGB retains the right to make specification amendments or improvements to the technical data without prior announcement.

Edition 2022 (This edition replaces earlier editions which hereby lose their validity).

STATEMENT REGARDING LEAD CONTENT IN GGB PRODUCTS & EU DIRECTIVE COMPLIANCE

GGB is committed to adhering to all U.S., European and international standards and regulations with regard to lead content. We have established internal processes that monitor any changes to existing standards and regulations, and we work collaboratively with customers and distributors to ensure that all requirements are strictly followed. This includes RoHS and REACH guidelines.

GGB makes it a top priority to operate in an environmentally conscious and safe manner. We follow numerous industry best practices, and are committed to meeting or exceeding a variety of internationally recognized standards for emissions control and workplace safety.

Each of our global locations has management systems in place that adhere to IATF 16949, ISO 9001, ISO 14001 and ISO 45001 quality regulations.

All of our certificates can be found here:

<https://www.ggbearings.com/en/certificates>

A detailed explanation of our commitment to REACH and RoHS directives can be found at

<https://www.ggbearings.com/en/who-we-are/quality-and-environment>

GGB Company History

SINCE 1899 GGB HAS IMPROVED SURFACE ENGINEERING TO MOVE THE WORLD FORWARD.

GGB began in 1899 as Glacier Antifriction Metal Company, producing plain bearings and introducing many successful new products to the market, including internationally recognized polymer materials. Over all these years, our company has continued forming strategic partnerships, continuously expanding into a global network of manufacturing facilities, increasing production capabilities and resources to become who we are today: world leaders in tribological innovation.

Today, our products can be found everywhere—from scientific vessels at the bottom of the ocean to race cars speeding down the tarmac to jumbo jets slicing through the sky to the Curiosity rover exploring the surface of Mars.

Throughout our history, safety, excellence and respect have formed the foundational values for the entire GGB family. They are of paramount importance as we seek to maximize personal possibility, achieve excellence and establish open, creative work environments with the highest safety standards in the industry.

SAFETY

GGB's deep-rooted culture of safety places a relentless focus on creating a secure, healthy work environment for all. A core value of GGB, safety is critical at all levels of business in order to achieve our goal of having the safest employees in the industry.

EXCELLENCE

A world-class organization is built by fostering excellence throughout the company, across all roles. Our world-class manufacturing plants are certified in quality and excellence in the industry according to ISO 9001, IATF 16949, ISO 14001 and ISO 45001, allowing us to access the industry's best practices while aligning our quality management system with global standards.

RESPECT

We believe that respect is consistent with the growth of individuals and groups. Our teams work together with mutual respect regardless of background, nationality or function, embracing the diversity of people and learning from one another.



PUSHING BOUNDARIES TO CO-CREATE
A HIGHER QUALITY OF LIFE



GGB HEILBRONN GMBH

Ochsenbrunnenstr. 9 | D-74078 Heilbronn

Tel: +49 7131 269 0

<https://www.ggbearings.com>



IN201ENG04-22HN